

# INSTALLATION MANUAL

# Innolumis

INSTALLATIEHANDLEIDING  
 INSTRUCTIONS DE MONTAGE  
 MONTAGEANLEITUNG  
 ISTRUZIONI DI MONTAGGIO  
 INSTRUCCIONES DE MONTAJE



MINI  
 MAXI **Victoria**



<b>IEC</b> EN60598	IP66	IK09	220-240VAC 50-60Hz					
-----------------------	------	------	-----------------------	--	--	--	--	--

## MINI Victoria

 4,7kg	Cd x S 0.029m <sup>2</sup>	
-----------	-------------------------------	--



## Victoria

 7,5kg	Cd x S 0.039m <sup>2</sup>	
-----------	-------------------------------	--

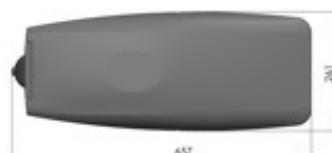

## MAXI Victoria

 13,8kg	Cd x S 0.047m <sup>2</sup>	
------------	-------------------------------	--

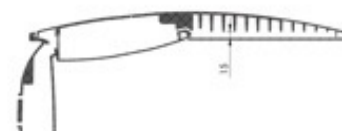

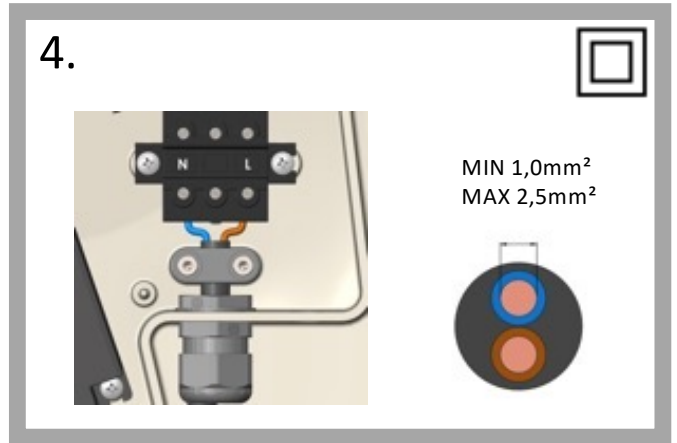
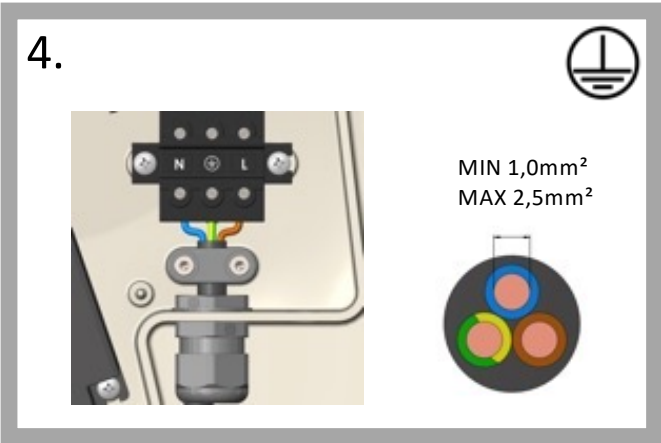
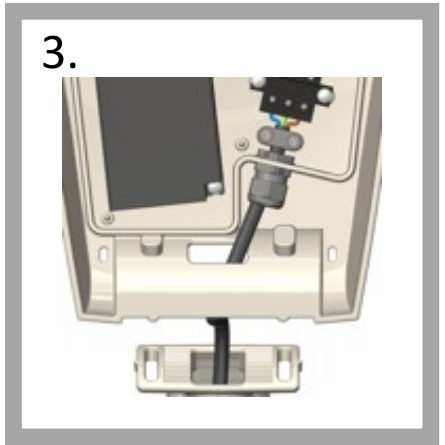
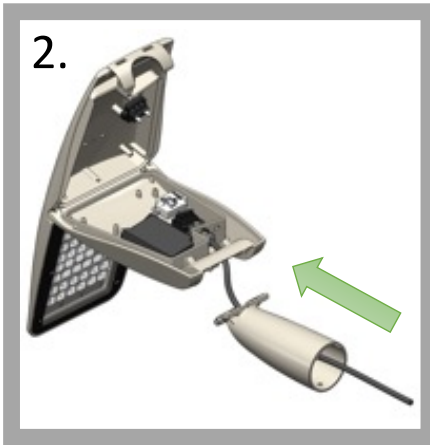
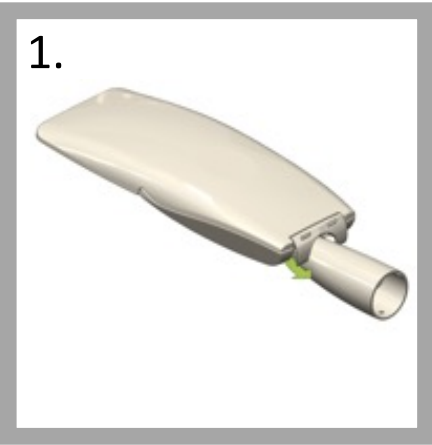
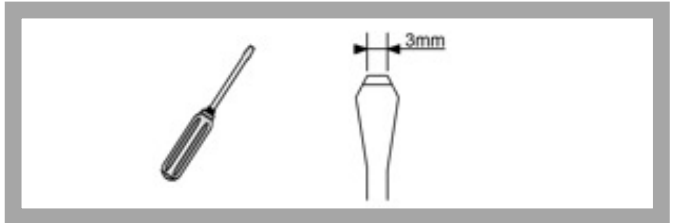
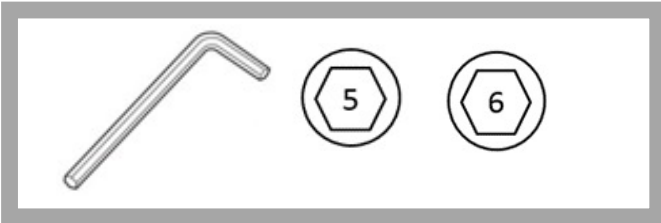

**USE CORRECTLY RATED POWERCORD, ACCORDING TO LOCAL LEGISLATION**  
**ALWAYS USE FERRULES WHEN CONNECTING THE POWERCORD TO THE LUMINAIRE**  
**CHECK MARKINGS ON POWERENTRY CONNECTOR WHEN CONNECTING THE POWERCORD**

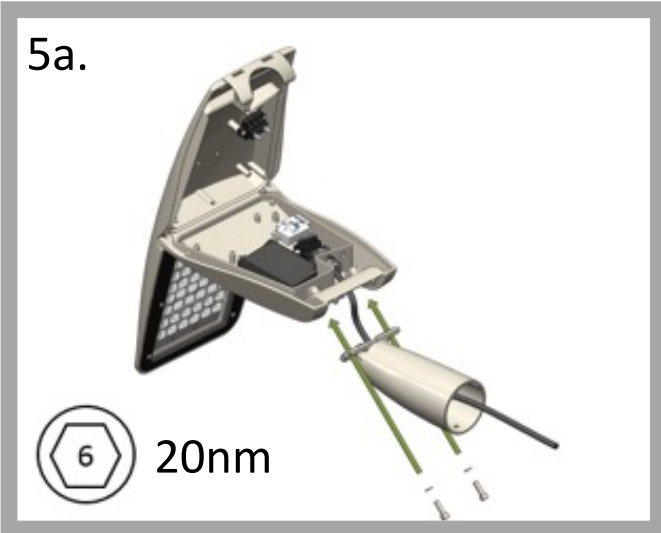

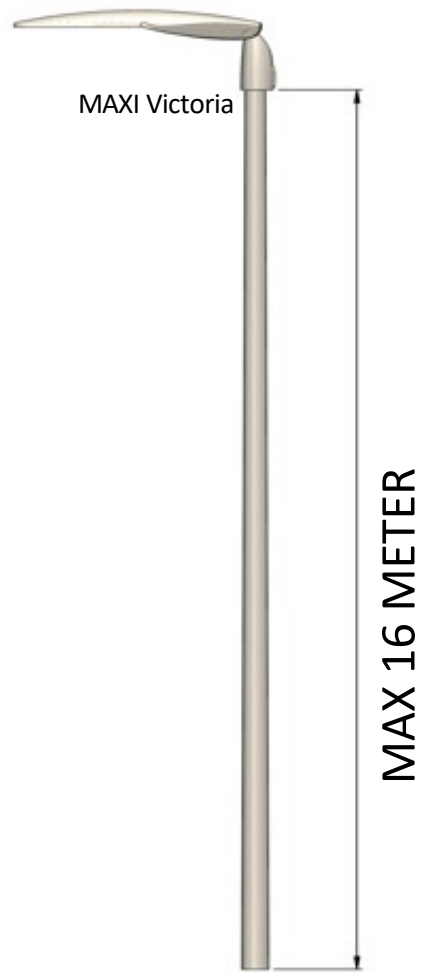
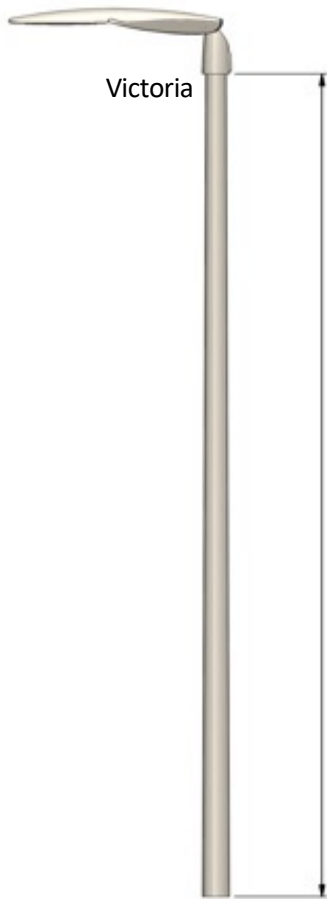
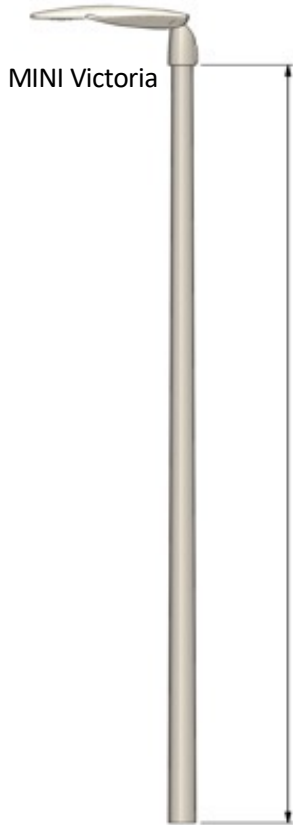
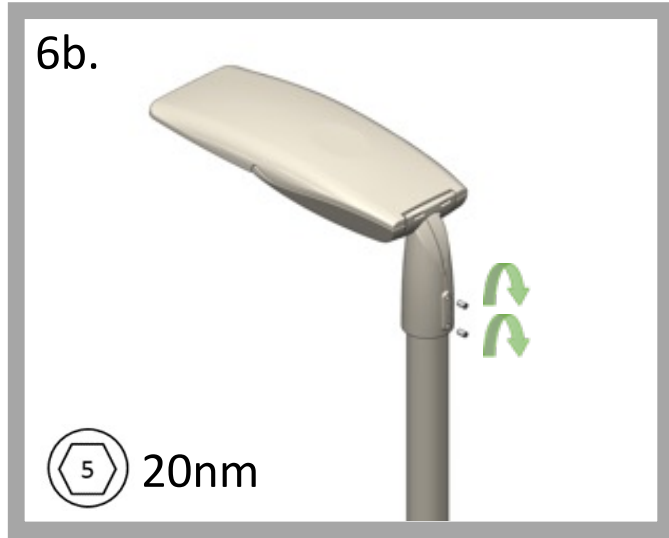
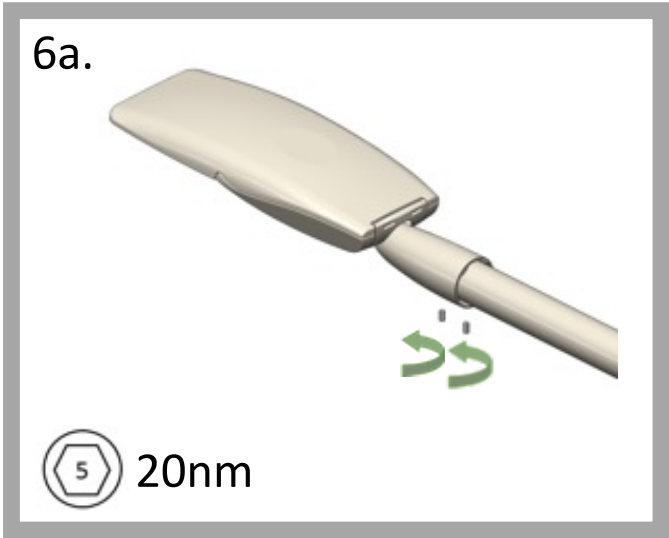

**Innolumis Public Lighting**  
 Ariane 2  
 3824 MB Amersfoort  
 the Netherlands  
 T +31 (0)33 760 04 34  
 F +31 (0)33 760 01 35  
 E info@innolumis.com

**Innolumis**

[www.innolumis.com](http://www.innolumis.com)